



Whistle



COWCATCHER DIVISION

DIVISION ONE OF THE LONE STAR NMRA REGION

July 2022

Tower 55 in Fort Worth

with Ken Fitzgerald

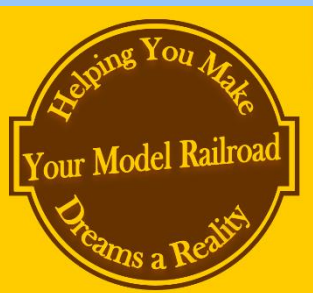

In This Issue:

- July's Meeting ...Cover
- Director's Report1
- Treasurer's Report1
- July's Clinic2,3
- Wifi Throttles4-6
- Calendar of Events7
- Winfield Prints8
- Area Clubs9
- Area Hobby Shops10



July's meeting will be Saturday, July 9th at the Texas Western Model RR Club and via zoom.

Wifi Throttles Using NCE Command Station with WifiTrax WFD-30

By Steve Gratke

The address for TWMRC is
6808 Forest Hill Drive,
Forest Hill, Texas 76140.

See Mike Mackey's email for the zoom link

Cowcatcher Division

Division One of the Lone Star NMRA Region



NMRA Lone Star Region
Cowcatcher Division 1

Whistle

Vol. 6 No. 7
July 2022

Director

Mike Mackey
director@cowcatcherdivision.org

Secretary

John "Trapper" Kirkpatrick
secretary@cowcatcherdivision.org

Treasurer

Dick Brannan
treasurer@cowcatcherdivision.org

Program Manager

Cole Rash
pm@cowcatcherdivision.org

Operations Manager

David Grein
ops@cowcatcherdivision.org

Achievement Program Manager

Lorrie Palitti
ap@cowcatcherdivision.org

Contest Advisor Co-Managers

Casey Akin
contest1@cowcatcherdivision.org
Cody Akin
contest2@cowcatcherdivision.org

Webmaster

Stephen Gradke
webmaster@cowcatcherdivision.org

Communications Manager

Dave Steckler
dsteckler@aol.com

Newsletter Editor

David Hager
editor@cowcatcherdivision.org

Videographer

David Kranda
video@cowcatcherdivision.org

Membership

David Crumpton
ceo@twmrc.org
Michael Ross
mross@txem.com

Director's Report

Howdy everybody! Can you tell its July?

It's definitely time for a glass of sweet tea and relaxing in a cool shady spot.

What a great meeting in June! Many thanks

to our division Operation Team for putting together a fantastic summer social.

This month is a meeting you don't want to miss. Ken Fitzgerald is sharing a presentation of the history of Tower 55. Ken has some never-before-seen photos to show us as well as his inside story of a long connection to this historic and important railroad location.

Mark your calendar for the meeting this Saturday at 10am. Don't forget...

Bring a friend to the meeting!

Keep training!

Mike Mackey, MMR
Director, Cowcatcher Division



Treasurer's Report

As of the first of July, the Division has \$2784.83 in our primary checking account.

Dick Brannan
Treasurer

Cowcatcher Division

Division One of the Lone Star NMRA Region



SOUTHWEST O SCALE MEET

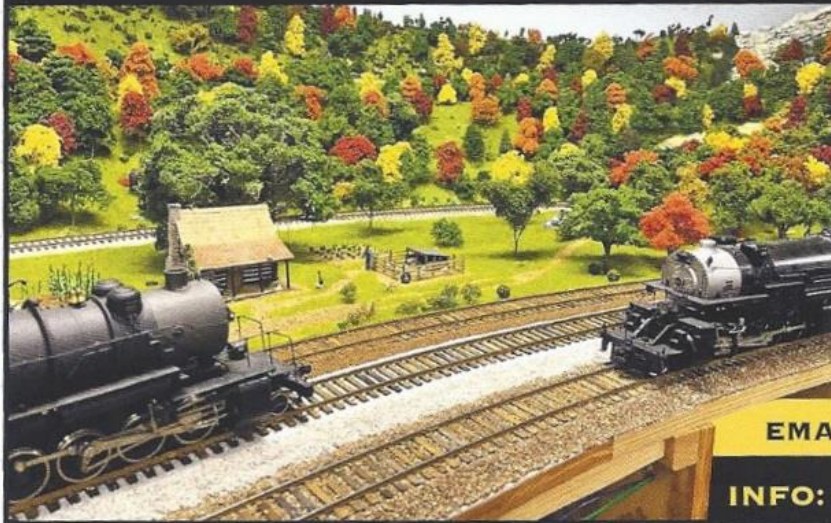

**OCTOBER 14TH-16TH, 2022
FORT WORTH, TEXAS**

- **TRADING, SALES, CLINICS**
- **TWO LAYOUTS ON SITE:
STANDARD AND TRACTION**
- **LAYOUT TOURS:
THREE O SCALE LAYOUTS
WITHIN FIVE MILES**

EMAIL: SWOSCALEMEET@GMAIL.COM

INFO: WWW.OSCALESW.COM

July's Clinic

Tower 55

with Ken Fitzgerald

Ken began his lifelong passion for railroads in 1960 at the age of five while spending his summers in Sweetwater, Texas riding Trains at the Santa Fe yard. Taking a photography course at age 12 allowed him to start capturing the railroad's people, operations, equipment, and character for historical purposes.

Since that time his photography has appeared in many different railroad magazines, books and calendars. He also authored the books "Dallas Then and Now" in 2014 and "Train Stations Then and Now" in 2017 along with doing the principal photography for the Houston, San Antonio, Austin and "Texas Then and Now" books. He has also produced several other photo books of his work that were written as internal publications for different railroad companies.

Cowcatcher Division

Division One of the Lone Star NMRA Region



July's Clinic continued from page 2



Today Ken works as a full-time photographer in the railroad industry. In 2019 alone he documented several major railroad engineering projects; the startup of the DFW TEXRail commuter service; the operation of Union Pacific's "Big Boy" steam locomotive across south Texas; the CSX Santa Train as celebrity Marty Stuart's personal photographer; and BNSF's Holiday Express across the Pacific Northwest. Ken is also an HO scale model railroader and locomotive horn collector.

Join us as Ken gives his presentation on the history and current fate of the real Tower 55. It will include photos from the old days and the 2014 major track realignment along with current events in progress leading to the eventual dismantling of the tower.

Cole Rash

Program Manager

Cowcatcher Division

Division One of the Lone Star NMRA Region



Wifi Throttles Using NCE Command Station with WifiTrax WFD-30

By Steve Gratke

One of the granddaughters and I were running two trains with my NCE Power Cab. We handed the throttle back and forth. After that fun, I bought a Cab 06 so we could each have our own throttle. A few months later I realized 3 of us could run 3 trains at once but again we had to hand throttles around. I decided to look into what my options were to have a third (or more) throttle(s). There were several options.

My layout is modular at 9'X10'. It is nothing to be excited about - it has no scenery. It has 14 turnouts, 2 crossings, a reverse wye, a reverse loop, and a few sidings - it is constantly changing as I figure out just where I am going. It is just for the fun of running trains.

I chose a WifiTrax WFD-30 NCE Cab Bus Wifi Interface Module after lots of reading on the net plus watching several YouTube videos. The WFD-30 is an Australian product available in the USA only from Iron Planet Hobbies (<https://www.ironplanethobbies.com/>). This is a NCE CAB Bus compatible product that works with any NCE Command Station such as PowerPro, Smart Booster, or PowerCab to provide Wifi Control of trains using popular apps such as WiThrottle on Apple or Engine Driver on Android. If you don't like touch screens, the TCS UWT-100 or UWT-50 Universal Wifi Throttles can be used.

Cowcatcher Division

Division One of the Lone Star NMRA Region



Wifi Throttles Using NCE Command Station with WifiTrax WFD-30 continued...

The WFD-30 acts as a WiThrottle server (like a Hot Spot) using Hoffman's WiThrottle protocol. You don't need to install JMRI anywhere - just connect to your NCE command station, install a recommended app on your Apple iPhone/iPad or your Android phone/tablet, connect to the WFD-30's Wifi "hot spot" and start driving trains. The WFD-30 supports 4 wireless throttles but can be connected to a home or model railroad network to increase the Wifi throttle count to 8. JMRI can then be brought into the action if desired. Pictured below is the WifiTrax WFD-30 (figure 1). It is about 2.2" X 2.2" X 0.5".



Figure 1: WifiTrax WFD-30

Cowcatcher Division

Division One of the Lone Star NMRA Region



Wifi Throttles Using NCE Command Station with WifiTrax WFD-30 continued...

There are several ways to hook this device up to a Power Cab. I chose the least cost method which I have diagrammed in figure 2.

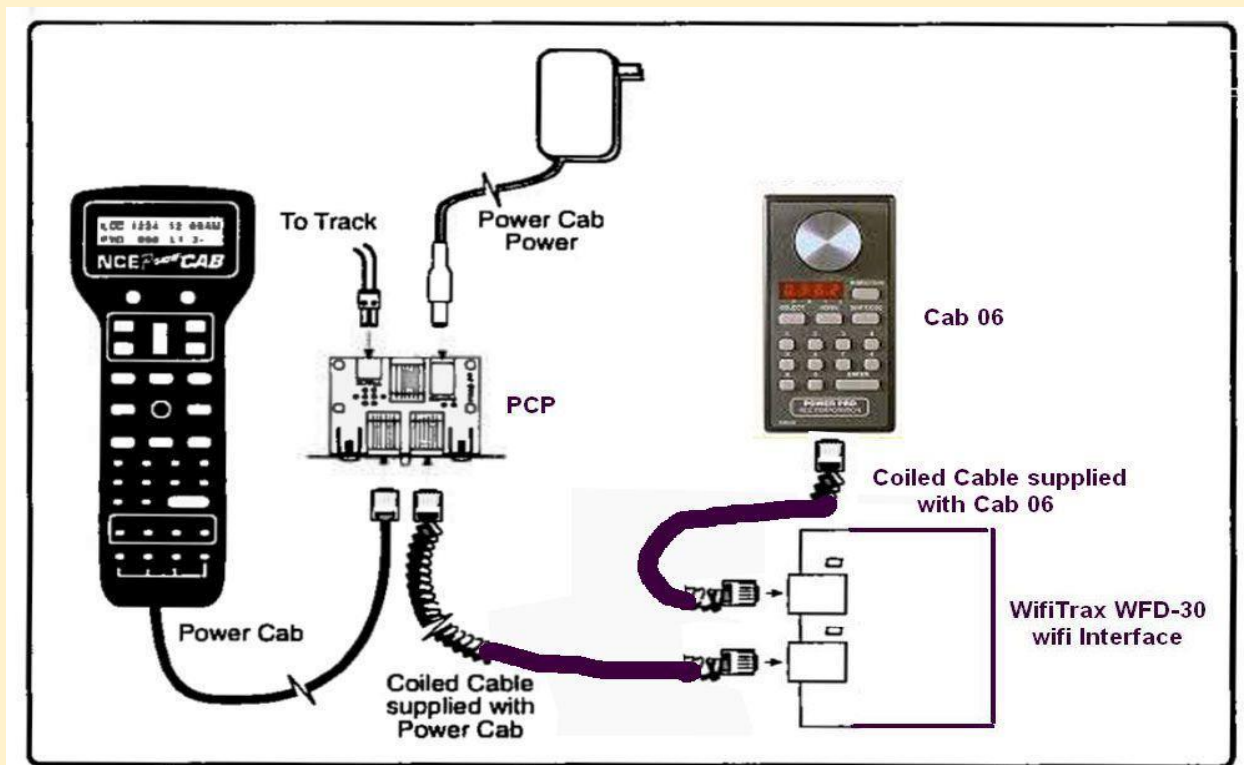

Figure 2: WifiTrax WFD-30 connected to a Power cab

I am using an old iPhone running WiThrottle. It is pretty neat and works well. However, I do miss the knob. I have read some articles about adding a USB volume control knob to an Android phone and configuring it to act as a knob throttle running Engine Driver. Maybe a future project is to find an old Android phone and order a USB volume control.

Cowcatcher Division

Division One of the Lone Star NMRA Region



July 2022

9th – NMRA Lone Star Region
Cowcatcher Division 1 Meeting,
10 am - 1pm

www.cowcatcherdivision.org

16th – NMRA Lone Star Re-
gion Division 3 Meeting, Christ The
Servant Lutheran Church in Allan,
TX, 10am - 1pm, Saturday

www.trinityriverdivision.org

16th – Cowtown Model RR
Club General Meeting, Handley
Center, 3024 Forest Avenue, Ft
Worth, TX 76112, 7pm - 9pm,

<https://www.cmrrc.net>

23rd – NMRAx

August 2022

4th – Texas Western Model RR
Club Business Meeting for
Members and Prospective
Members Only, 7 pm - 9 pm @

6808 Forest Hill Dr,
Forest Hill, TX 76140

Thursday

www.twmrc.org

13th – NMRA Lone Star
Region Cowcatcher Division 1
Meeting, 10 am - 1pm

www.cowcatcherdivision.org

20th – NMRA Lone Star Re-
gion Division 3 Meeting, Christ The
Servant Lutheran Church in Allan,
TX, 10am - 1pm, Saturday

www.trinityriverdivision.org

20th – Cowtown Model RR
Club General Meeting, Handley
Center, 3024 Forest Avenue, Ft
Worth, TX 76112, 7pm - 9pm,

<https://www.cmrrc.net>



Gateway 2022

NMRA National Convention

Sun, August 07 — Sat, August 13, 2022

[https://www.eventsquid.com/event.cfm?previ
ew&event_id=13724](https://www.eventsquid.com/event.cfm?previ
ew&event_id=13724)

Regional Train Shows

Austin August 27 & 28, 2022

<https://austintrainshow.org>

Temple September 17 & 18, 2022

<http://centramodrr.com/train-show>

Plano October 1 & 2, 2022

<http://www.dfwtrainshows.com>

New Braunfels October 22 & 23, 2022

<http://newbraunfelsrailroadmuseum.org/nbrr/train-shows>

Oklahoma City November 5 & 6, 2022

<https://www.oklahomarailwaymuseum.org/events/okc-train-show/>

Greater Houston February 18, 2023

<http://www.sanjacmodeltrains.org/GHTS.php>

AUSTIN 2022 TRAIN SHOW



Saturday August 27, 2022

10:00am to 5:00pm

Sunday August 28, 2022

10:00am to 4:00pm

Palmer Events Center

900 Barton Springs Road

Austin, Texas

Cowcatcher Division

Division One of the Lone Star NMRA Region



Winfield Prints Available

Fort Worth Crossroads



I received a call the other day from Jim King of the North Texas Chapter of the National Railroad Historical Society. It seems that the Winfield drawing photo we've been using on our website was actually commissioned by the local NRHS chapter for their 2008 national convention held here. Not a problem, in fact a blessing! They are thrilled that we are using the drawing on our site. As luck would have it, they have additional copies of the print which they have allowed us to sell as a division fund raiser.

Currently we have 18" x 24" prints available for \$25.00, and a VERY limited number of the same prints commemorating the 2008 convention that are signed and numbered for \$35.00.

As you are aware, this is a GREAT price on a Winfield print! To purchase your print, please email director@cowcatcherdivision.org with your preference, signed or not, and I'll respond so we can arrange payment and delivery.

Mike Mackey

Cowcatcher Division

Division One of the Lone Star NMRA Region



Area Model Railroad Clubs/News

Cowtown Model Railroad Club

Meets at the Handley Community Center, upstairs 3024 Forest Avenue, Ft Worth. Website: <https://www.cmrrc.net>

CLMRR

Meets Tuesdays, Thursdays & Saturdays. The layout is located at 3904 Vista Ridge Ln, Alvarado, TX 76009 For information please contact Lee Martin at [817-666-5367](tel:817-666-5367)

Dallas/Fort Worth O Scale Club

Normally meets two Saturdays per month in Richardson. Contact: Brady McGuire, Tel: [903-868-2726](tel:903-868-2726), Email: bradyprrm1a@cableone.net or contact: Stan Schwartz, Email: ss124@sbcglobal.net for dates and times.
1/48 12X41 lt/wt modular, 2-3 shows/year.

Denton Area Model Railroad Club

Meets the 2nd Tuesday of every month at 7 pm in the Denton Senior Center Downtown. HO & N Scale modular layouts. Facebook Page and Website: <https://www.facebook.com/damrrc/>

North Texas Chapter of the National Railway Historical Society

Meets 7:30 - 10:00 PM, First Tuesday of each month, often (but not always) at the Grapevine Tourist & Visitors Information Center at Main St. and the FWR railroad tracks. Website: <https://ntxnrhs.org>

Texas Western Model Railroad Club

Meets every Thursday & Saturday from 4 pm - 9 pm, Located at 6808 Forest Hill, 76140. Facebook Page: <https://www.facebook.com/texaswesternmodelrailroadclub/> Website: <https://www.twmrc.org>

Trinity N-Trak

Meets at Hobby World, Ft Worth at 6:30 PM. Check our website for time. Website: <https://www.trinitytrak.com>

TNMRC

Meets at 11999 Plano Rd, Suite 154, Dallas, 75243 Check our website for times. Website: <https://www.texasnorthern.org>

Cowcatcher Division

Division One of the Lone Star NMRA Region



Angelo Hobbies

5600 Rufe Snow Drive Dr. #106
North Richland Hills, TX 76180
<http://angelohobbystrains.com>

(817) 428-0190



Discount Model Trains

4641 Ratliff Lane
Addison, TX 75001

(817) 428-0190



Hobby World

5658 Westcreek Dr. Ste. #500
Fort Worth, TX 76133
<https://www.facebook.com/hobbyworldfw>

(817) 263-5750



Model Train Crossing

1113 W. Pipeline Road
Hurst, TX 76053

(817) 595-0800

<https://www.facebook.com/modeltraincrossin> (no "g" on the end)

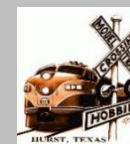

Hobbytown USA

746 Grapevine Hwy
Hurst, TX 76054

(817) 581-1027

<https://www.hobbytown.com/hurst-tx/1123>



Hobbytown USA

500 E. Round Grove Rd
Lewisville, TX 75067

(972) 315-3700

<https://www.hobbytown.com/lewisville-tx/121>



Wild Bill's Hobbytown USA

535 E Shady Grove Rd
Irving, TX 75060

(972) 438-9224

<https://www.hobbytown.com/irving-tx/1183>



Check with your local hobby shops for their store hours.

Cowcatcher Division

Division One of the Lone Star NMRA Region



Effective March 31, 2020, in accordance with the policy adopted by the National Model Railroad Association (NMRA) at its board meeting on March 7, 2020, Division 1 of the Lone Star Region of the NMRA, commonly known as the “Cowcatcher Division”, will require anyone under the age of 18, wishing to attend any division event, to be personally escorted by their parent or legal guardian. Additionally, the parent or legal guardian must sign a current document stating that they will remain in visual contact with their minor at all times.